

Best Buy NoHo

622 BROADWAY
NEW YORK, NY 10012

ROOFTOP HVAC EQUIPMENT REPLACEMENT
AND ACOUSTIC BARRIERS

prepared by

BWArchitects

611 BROADWAY, SUITE 311, NEW YORK, NY 10012



EXISTING CONDITIONS



SITE PLAN

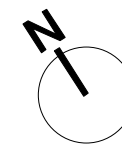

EXISTING CONDITIONS

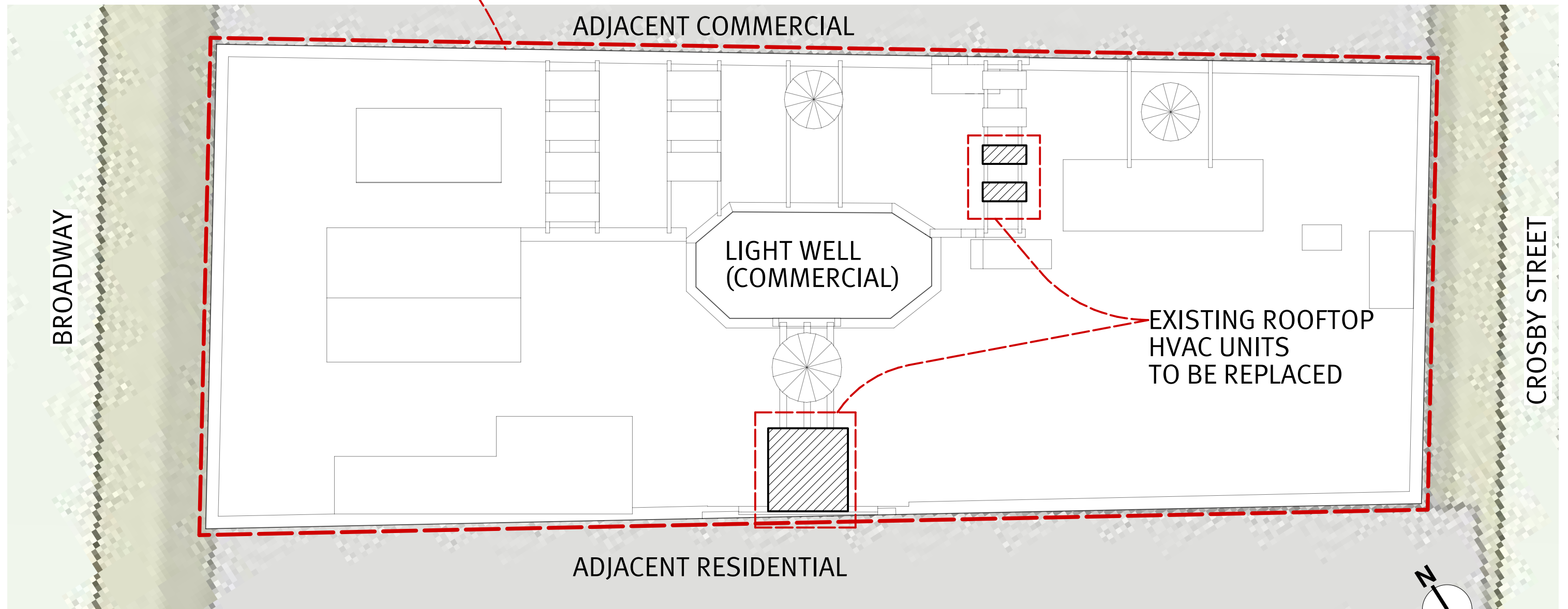
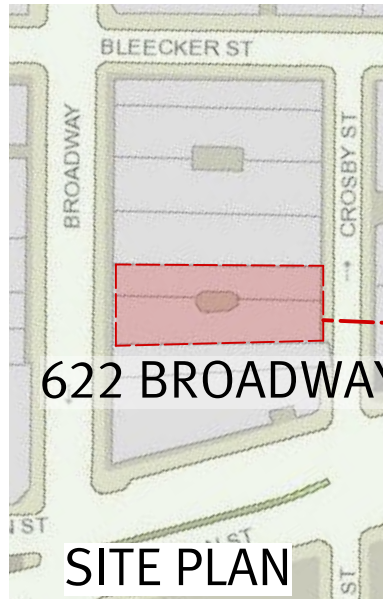

ROOF PLAN



EXISTING CONDITIONS



NORTH - CONDENSING UNITS



SOUTH - CHILLER UNIT

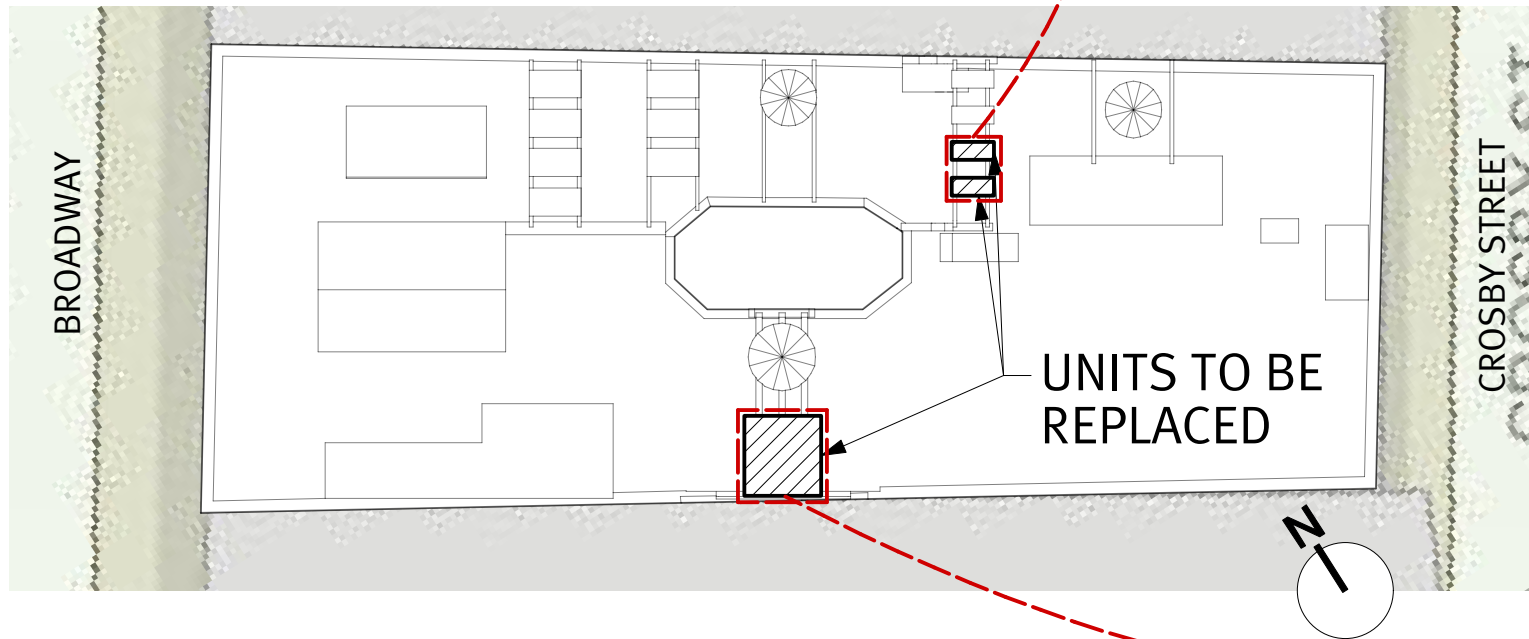

ROOF PLAN

PROPOSED



PER NYC NOISE CONTROL CODE, ALL NEW UNITS MUST CONTRAIN SOUND TRANSMISSION TO ADJACENT RESIDENTIAL OR COMMERCIAL UNITS.

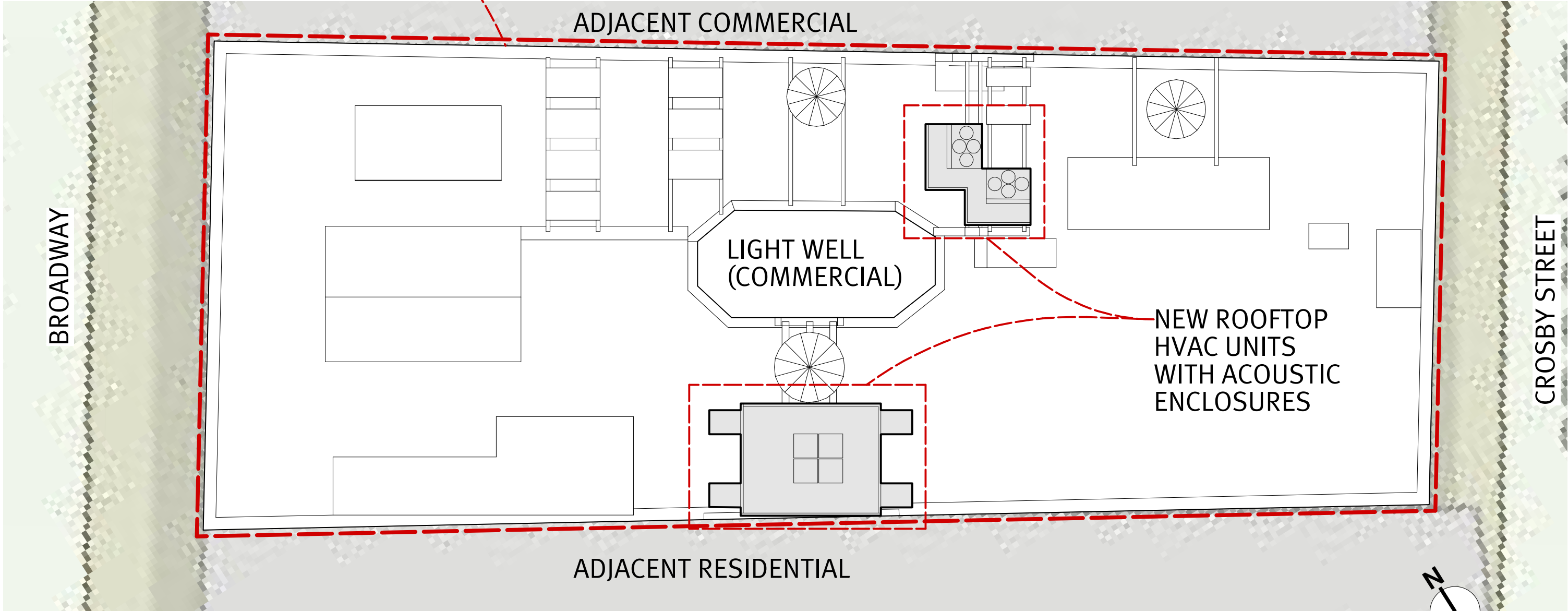

PROPOSED ROOF PLAN

PROPOSED (ROOFTOP, NORTH)

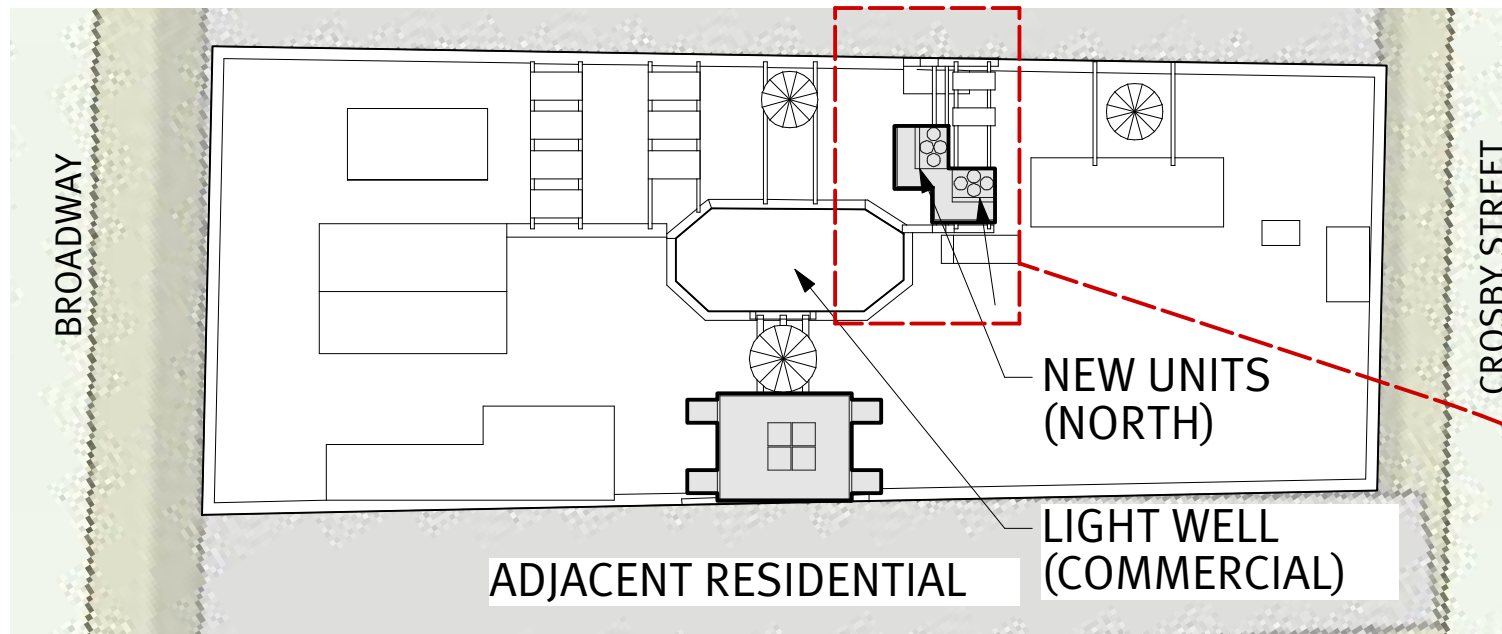

PROPOSED ROOF PLAN

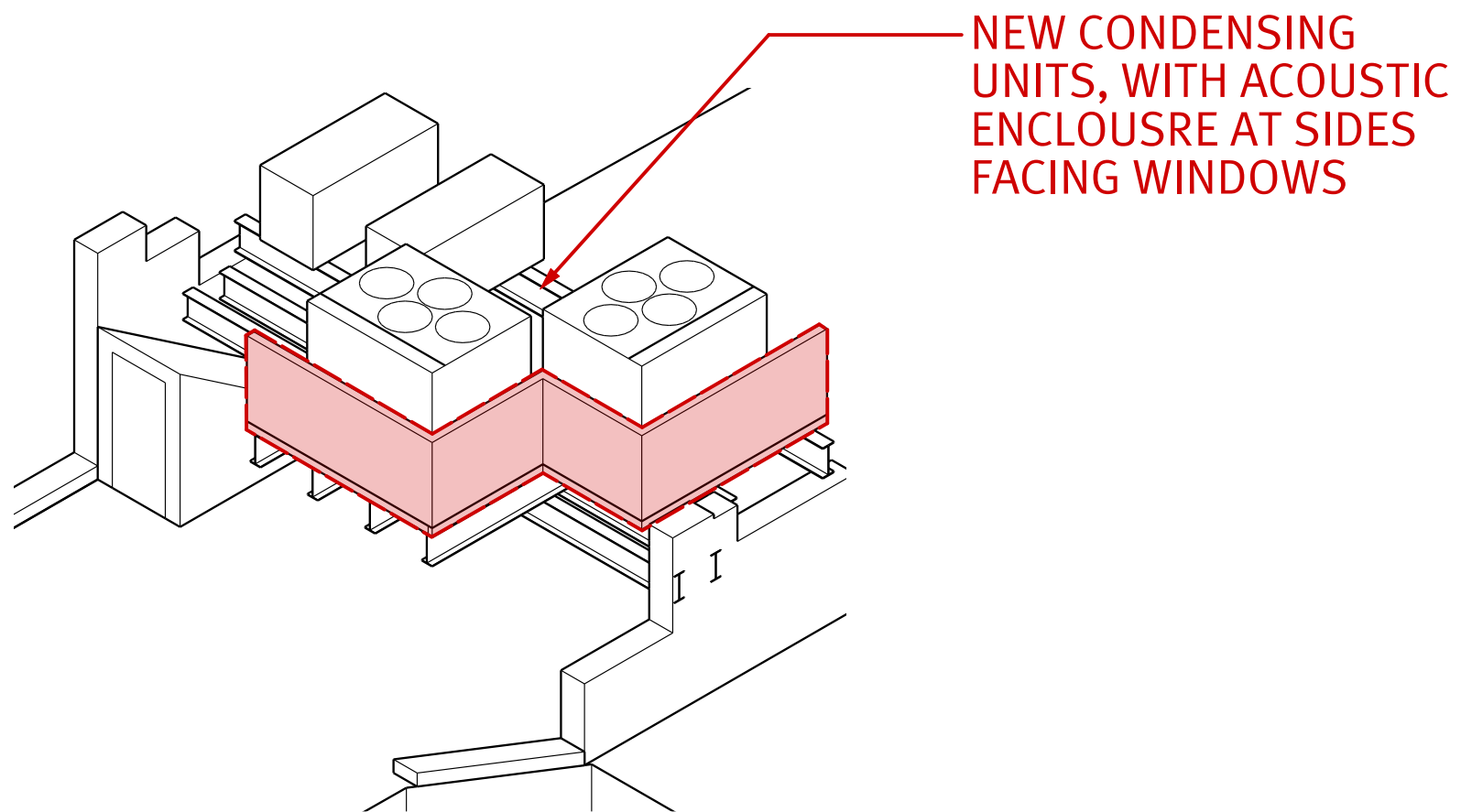

PERSPECTIVE VIEW

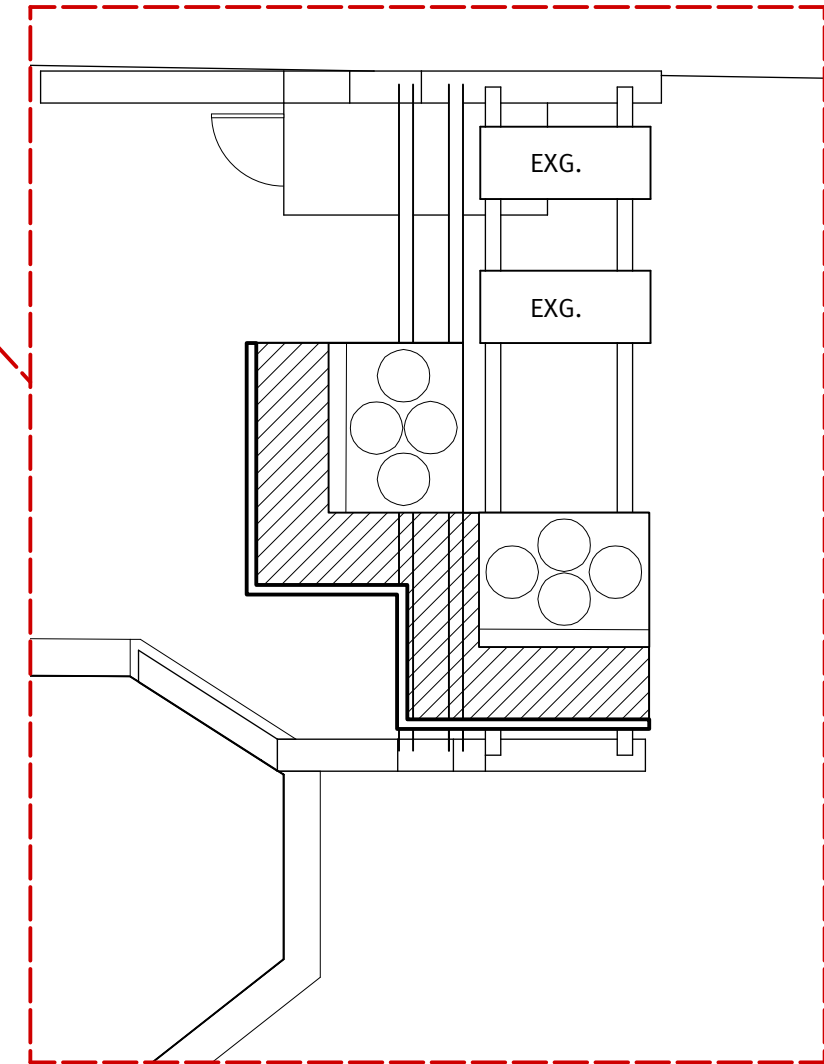

PROPOSED ROOF PLAN, DETAIL

PROPOSED (ROOFTOP, SOUTH)

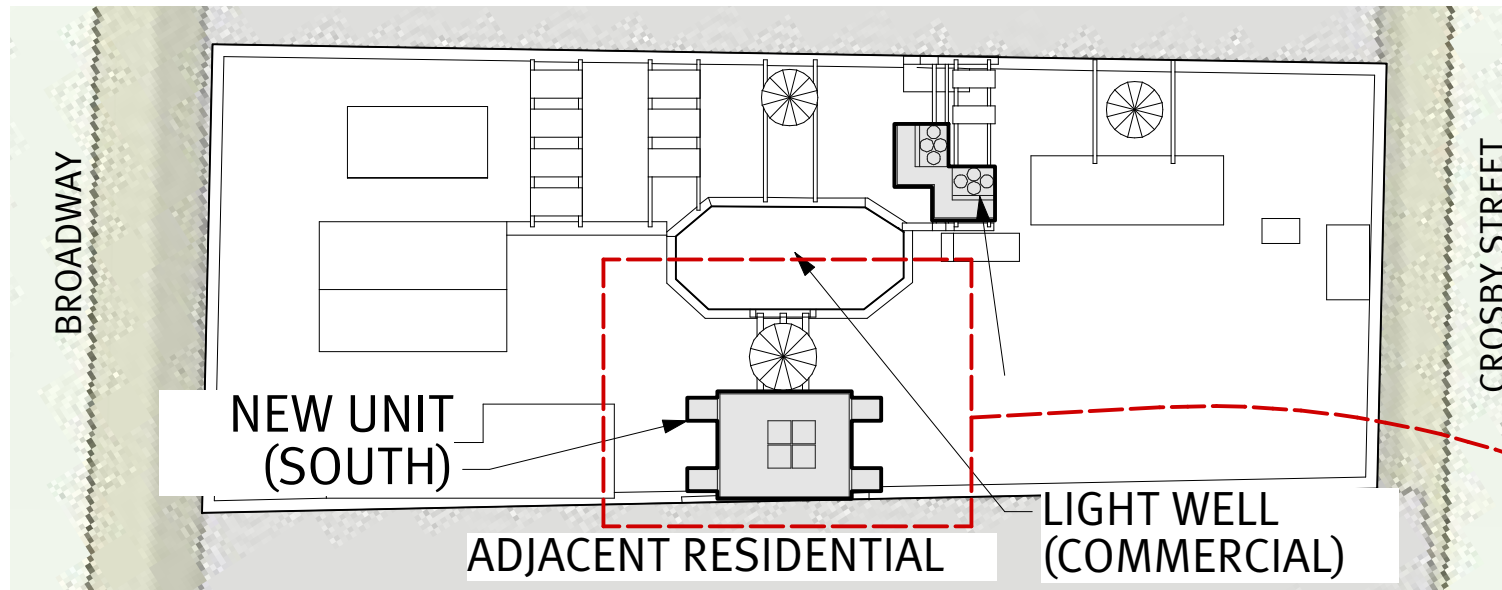

PROPOSED ROOF PLAN

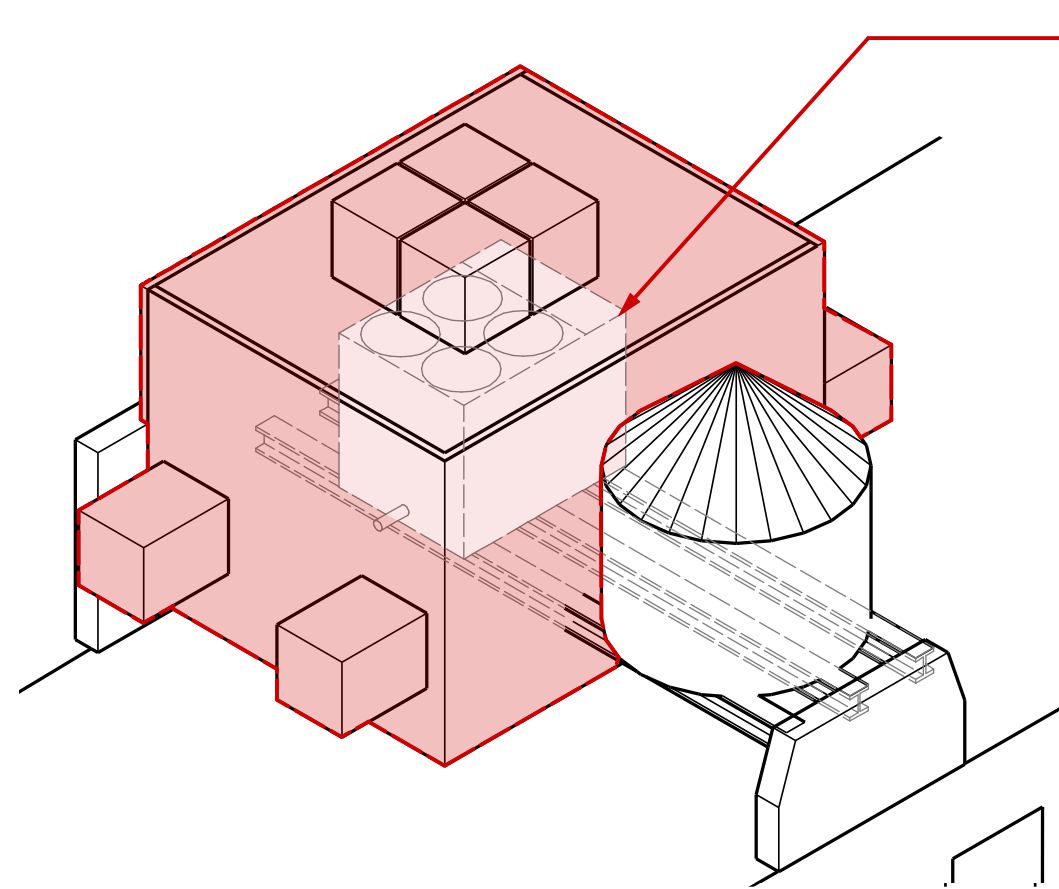

PERSPECTIVE VIEW

NEW CHILLER UNIT, WITH
ACOUSTIC ENCLASURE
ALL SIDES, TOP AND
BOTTOM

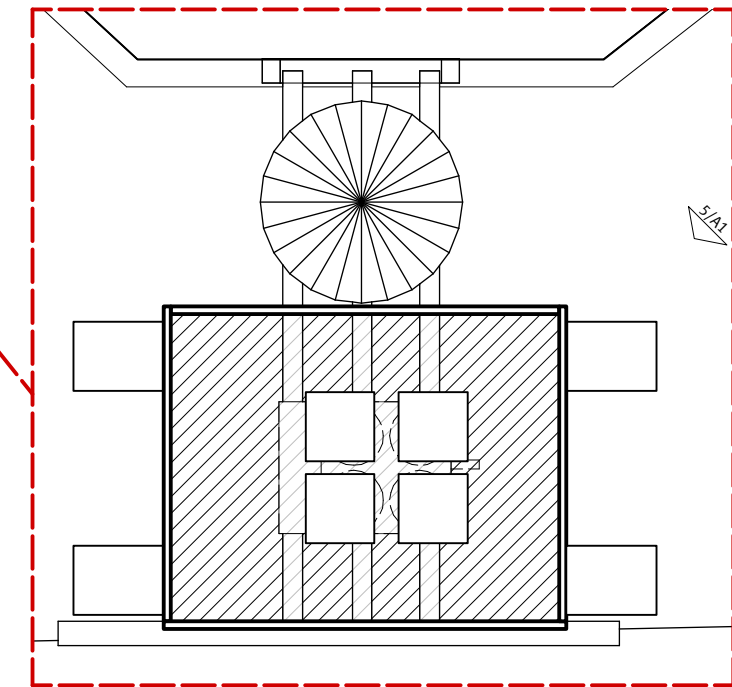

PROPOSED ROOF PLAN, DETAIL

PROPOSED

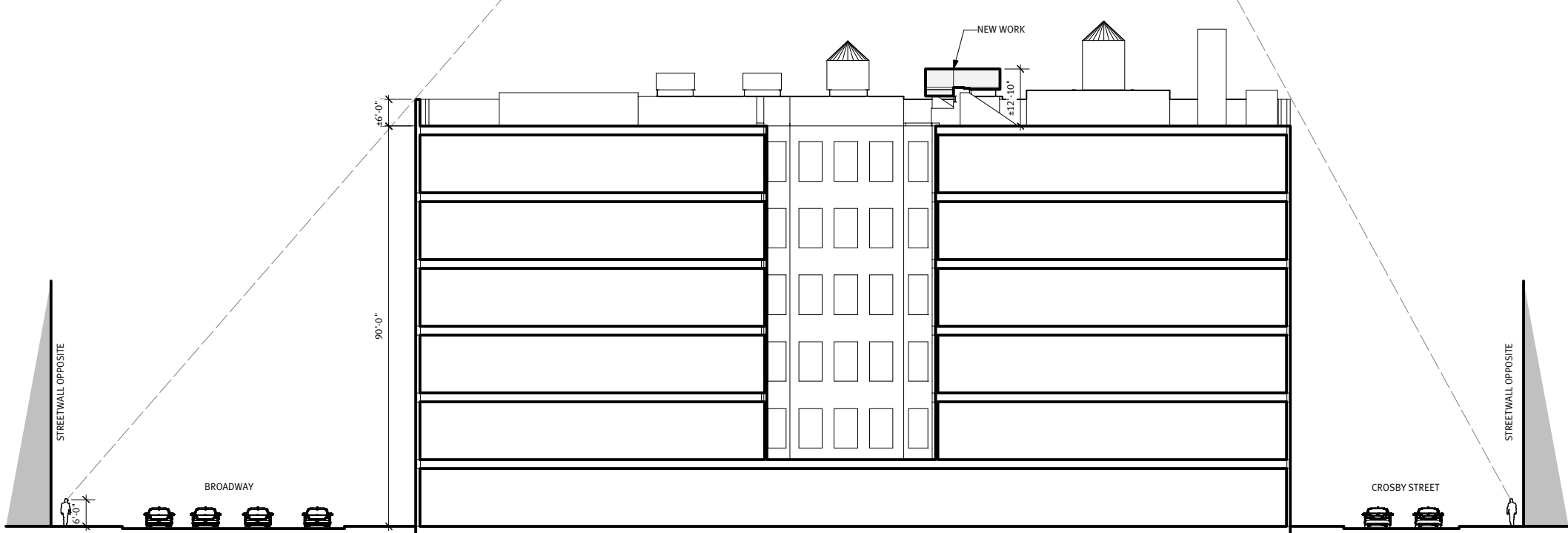

PROPOSED SECTION LOOKING NORTH

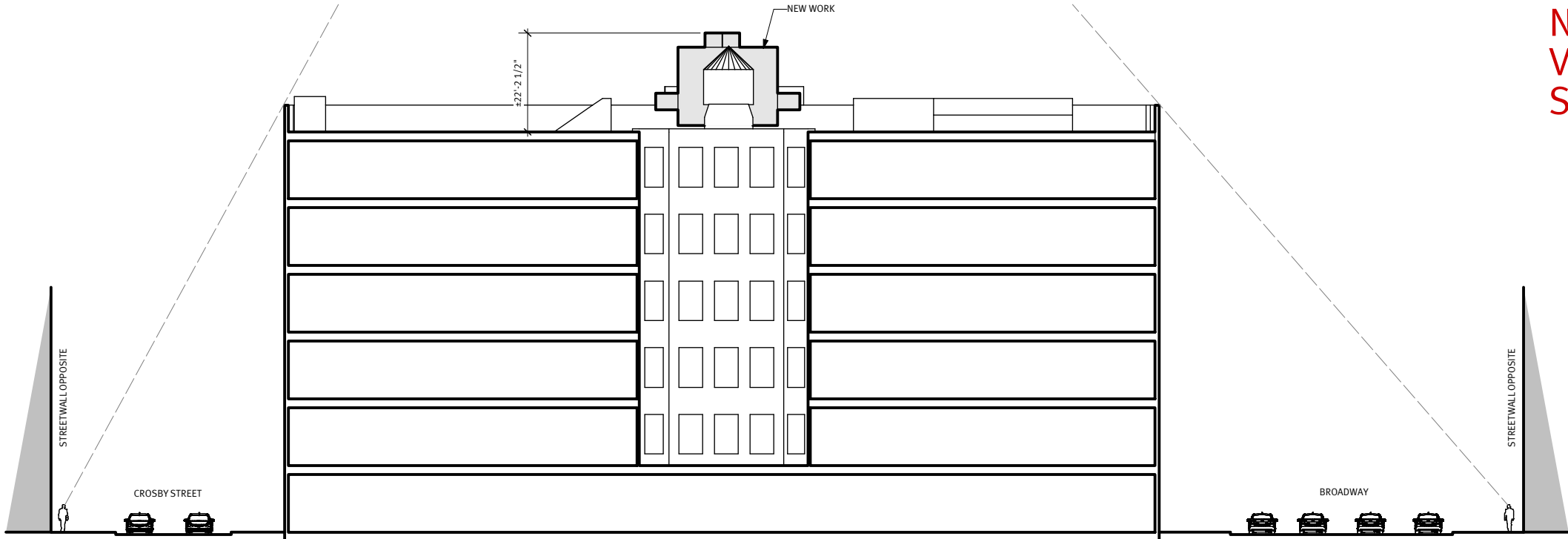

PROPOSED SECTION LOOKING SOUTH

NEW WORK IS NOT
VISIBLE FROM ADJACENT
STREETS

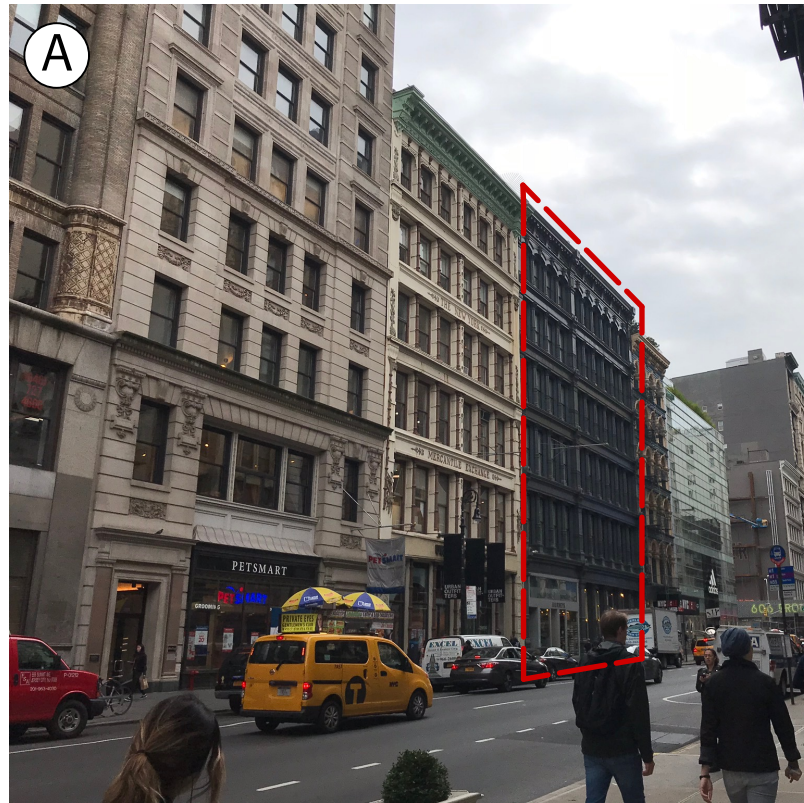

VIEW FROM NEIGHBORHOOD



SITE PLAN

NEW WORK NOT VISIBLE FROM BROADWAY





VIEW FROM NEIGHBORHOOD



SITE PLAN

NEW WORK NOT VISIBLE FROM CROSBY ST



VIEW FROM NEIGHBORHOOD

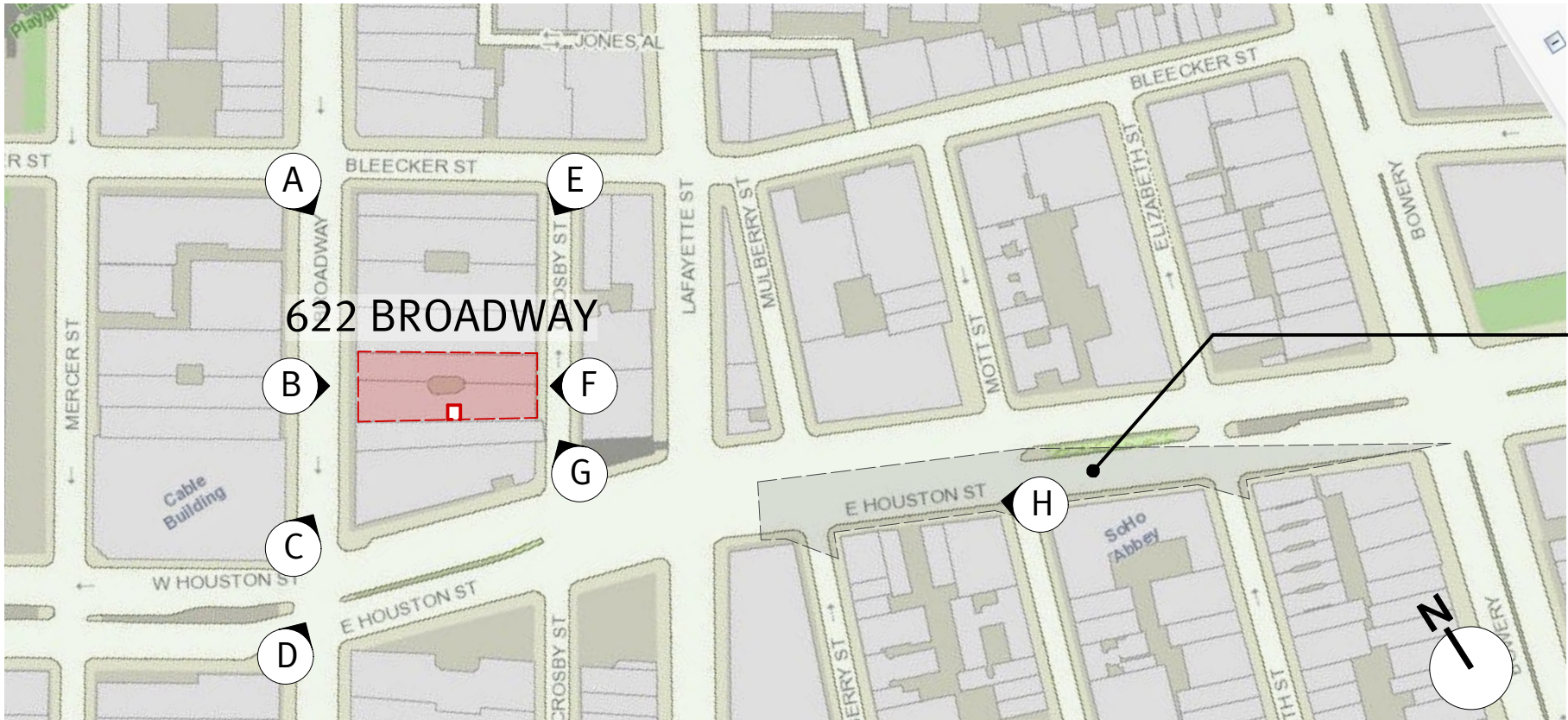

AREA OF VISIBILITY

SITE PLAN

SOUTH PORTION OF NEW WORK PARTIALLY VISIBLE FROM HOUSTON STREET



VIEW FROM NEIGHBORHOOD



EXISTING

PROPOSED

Best Buy NoHo

622 BROADWAY
NEW YORK, NY 10012

ROOFTOP HVAC EQUIPMENT REPLACEMENT
AND ACOUSTIC BARRIERS

prepared by

BWArchitects

611 BROADWAY, SUITE 311, NEW YORK, NY 10012

